

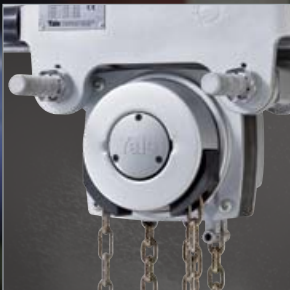

HURRICANE™

HAND CHAIN HOIST



LIFT AND POSITION FROM VIRTUALLY ANY ANGLE.

Because of its unique design, the versatility and safety benefits of the CM Hurricane 360° beats the competition. This one-of-a-kind hand chain hoist is ideal for use in the following applications:

TIGHT SPACES

where the rigid handle of a lever hoist would be difficult to maneuver and operate. The Hurricane 360° allows you to easily work around obstructions.

ABOVE THE LOAD

where traditional hoists cannot be used. The Hurricane 360°'s rotating hand chain guide allows for operation from virtually any angle.

DRIFTING APPLICATIONS

when the hand chain angle needs to adjust throughout the operation. Using two Hurricane 360° hoists in tandem, operators can easily drift loads from one location to another.

TO MAINTAIN SAFE DISTANCE

while handling a load. The rotating chain guide on the Hurricane 360° lets you conveniently maneuver a load without standing under or near it.



TABLE OF CONTENTS

- | | | | |
|---|--|----|--|
| 4 | CM HURRICANE 360°
Hook-mounted hoist models | 14 | YALELIFT 360° ATEX
Hook-mounted and army-type,
integrated trolley hoist models
with explosion protection, spark
resistance and corrosion resistance |
| 8 | CM HURRICANE 360°
Army-type, integrated trolley hoist models | | |





HURRICANETM

HAND CHAIN HOIST

360°

The CM Hurricane 360° is unlike any other hand chain hoist on the market today. Featuring a one-of-a-kind hand chain cover, the CM Hurricane 360° provides flexibility and versatility for challenging applications.

The Hurricane's patented hand chain cover rotates a full 360 degrees, allowing loads to be lifted, positioned or pulled from virtually any angle – even in confined spaces. It also permits the operator to stand safely away from the load, helping to prevent accidents and injuries.

HOOK-MOUNTED HOISTS

1/2 TO 20 TON CAPACITIES STANDARD LIFTS UP TO 30 FT.

BENEFITS & FEATURES

PATENTED HAND CHAIN COVER

Unique rotating hand chain cover allows the chain to rotate a full 360 degrees for safe and efficient operation from any direction. Cover design promotes smooth movement of the chain.

TRUSTED RELIABILITY & SAFETY

The Weston-style braking system provides positive load control and reliable performance. Standard load limiter provides simple, automatic overload protection to prevent injuries.

RUGGED & DURABLE FOR LONG LIFE

Internal gears and pinions are made of heat-treated steel for high strength and long life. Powder-coated finish provides protection against corrosion. Precision 4-pocket liftwheel and chain guide provide better chain fit and alignment to reduce wear.

EASE OF MAINTENANCE

Hoist requires minimal maintenance and can be easily disassembled with standard tools.

FAST & EASY PARTS ACCESS

Genuine CM Hurricane 360° parts are available in Total Repair Kits and convenient bulk packaging through CM Parts Star™.

MEETS ASME B30.16 & EUROPEAN CE STANDARD

ADDITIONAL OPTIONS AVAILABLE

Units are available with a variety of options to suit your application, including:

- Chain containers
- Zinc-plated load and hand chain
- Latchlok hooks
- Without standard load limiter



**LIFETIME
WARRANTY**

CM Hurricane 360° Hook-Mounted Hoist | 20-TON CAPACITY



The CM Hurricane 360° is available as a **hook-mounted hoist** in capacities from 1/2 to 20 tons, with standard lifts up to 30 feet.



1/2-TON
CAPACITY

1-TON
CAPACITY

2-TON
CAPACITY

3-TON
CAPACITY

5-TON
CAPACITY



10-TON
CAPACITY



15-TON
CAPACITY



20-TON
CAPACITY

HOOK-MOUNTED HOISTS

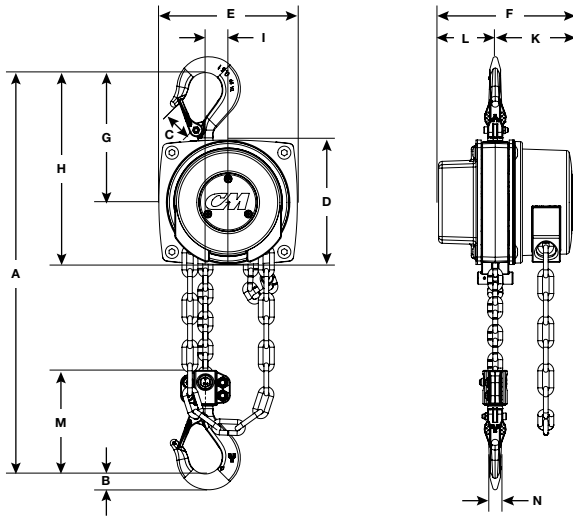

HOOK-MOUNTED HOIST
1/2 TO 3 TON

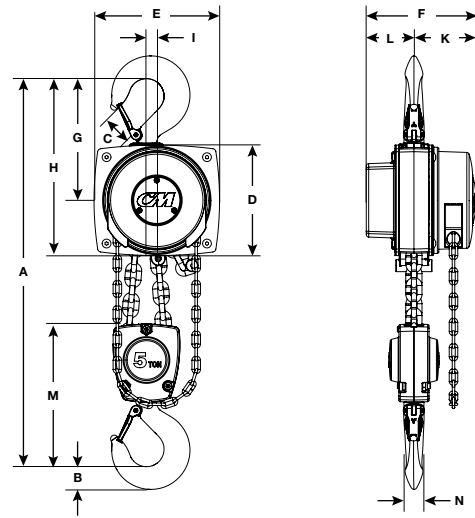

HOOK-MOUNTED HOIST
5 TON

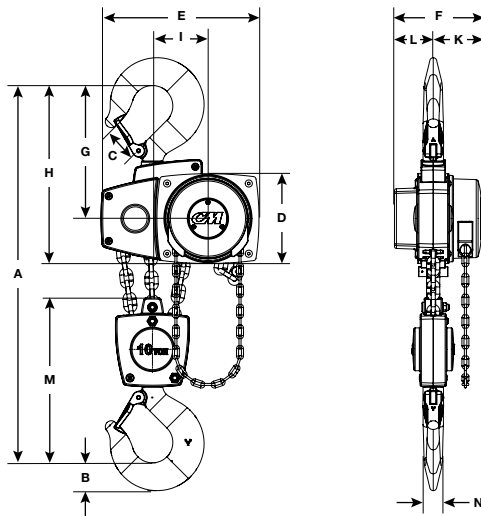

HOOK-MOUNTED HOIST
10 TON

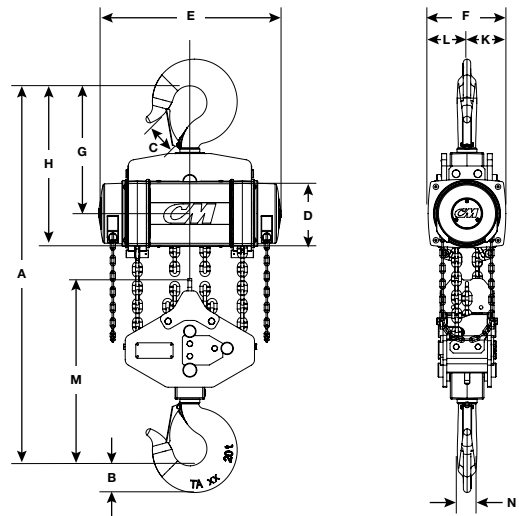

HOOK-MOUNTED HOIST
15 & 20 TON



The CM Hurricane 360's unique rotating hand chain cover allows the chain to rotate a full 360 degrees for safe and efficient operation from almost any angle or direction.

SPECIFICATIONS & DIMENSIONS

Product Code	Capacity Ton (kg)	Lift		Weight lbs. (kg)	Reeving	Hand Chain Pull to Lift Rated Load lbs. (kg)	Hand Chain Overhauled to Lift Load One Foot ft. (m)	Dimensions in inches (mm)												
		ft.	m					A	B	C	D	E	F	G	H	I	K	L	M	N
5623A	1/2 (500)	10	3	21 (9)	1	44 (20)	30 (9.1)	11.811 (300)	0.669 (17)	0.945 (24)	5.236 (133)	5.827 (148)	5.827 (148)	5.472 (139)	8.110 (206)	0.945 (24)	2.402 (61)	3.425 (87)	4.331 (110)	0.551 (14)
5624A		15	4.5	23 (10)																
5625A		20	6	25 (11)																
5651A		30	9	29 (13)																
5632A		Less Chain		17 (8)																
5626A	1 (1,000)	10	3	28 (13)	1	54 (24)	49 (14.9)	13.189 (335)	0.866 (22)	1.142 (29)	6.142 (156)	6.890 (175)	6.575 (167)	6.457 (164)	9.528 (242)	0.945 (24)	2.756 (70)	3.819 (97)	4.921 (125)	0.748 (19)
5627A		15	4.5	31 (14)																
5628A		20	6	34 (15)																
5653A		30	9	40 (18)																
5633A		Less Chain		23 (10)																
5629A	2 (2000)	10	3	47 (21)	1	74 (34)	71 (21.6)	15.551 (395)	1.181 (30)	1.378 (35)	7.165 (182)	7.992 (203)	7.638 (194)	7.559 (192)	11.142 (283)	1.220 (31)	3.268 (83)	4.370 (111)	6.142 (156)	0.866 (22)
5630A		15	4.5	52 (24)																
5631A		20	6	57 (26)																
5634A		Less Chain		36 (16)																
5635A		10	3	75 (34)																
5636A	3 (3,000)	15	4.5	82 (37)	1	92 (42)	87 (26)	20.472 (520)	1.496 (38)	1.575 (40)	8.661 (220)	9.843 (250)	8.622 (219)	8.858 (225)	13.189 (335)	1.339 (34)	3.740 (95)	4.882 (124)	7.008 (178)	1.181 (30)
5637A		20	6	89 (40)																
5638A		Less Chain		52 (24)																
5639A		10	3	106 (48)																
5640A		15	4.5	121 (55)																
5641A	5 (5,000)	20	6	136 (62)	2	76 (34)	174 (53)	25.748 (654)	1.772 (45)	1.850 (47)	8.661 (220)	9.843 (250)	8.622 (219)	9.528 (242)	13.858 (352)	0.827 (21)	3.740 (95)	4.882 (124)	11.220 (285)	1.457 (37)
5642A		Less Chain		74 (34)																
5643A		10	3	217 (98)																
5644A		15	4.5	240 (109)																
5645A		20	6	261 (118)																
5646A	Less Chain		168 (76)																	
HU15000H10	15 (15,000)	10	3	455 (206)	6	2 x 76 (2 x 34)	522 (2 x 261) (159.1 (2 x 79.3))	43.543 (1106)	3.386 (86)	3.150 (80)	8.661 (220)	23.071 (586)	9.843 (250)	16.181 (411)	20.512 (521)	-	4.921 (125)	4.921 (125)	23.740 (603)	2.480 (63)
HU15000H15		15	4.5	508 (230)																
HU15000H20		20	6	554 (251)																
HU15000H30		30	9	653 (296)																
HU20000H10		10	3	455 (206)																
HU20000H15	20 (20,000)	15	4.5	508 (230)	6	2 x 102 (2 x 46)	522 (2 x 261) (159.1 (2 x 79.3))	43.543 (1106)	3.386 (86)	3.150 (80)	8.661 (220)	23.071 (586)	9.843 (250)	16.181 (411)	20.512 (521)	-	4.921 (125)	4.921 (125)	23.740 (603)	2.480 (63)
HU20000H20		20	6	554 (251)																
HU20000H30		30	9	653 (296)																

Other lifts available. Contact factory.
Standard Hand Chain drop 2 ft. less than Lift.

DEMAND GENUINE PARTS

When you choose Parts Star™ by Columbus McKinnon, you'll be purchasing genuine Columbus McKinnon parts designed to fit the Hurricane 360° hoist's exact specifications, maintaining warranty requirements and the integrity of the unit's superior design and safety features.

Get everything you need for a complete and professional repair with Parts Star Total Repair Kits. Popular Hurricane 360° repair parts are also available in easy-to-order bulk packaging so the parts you need are always on hand.



PROTECT AGAINST UNSAFE LIFTING CONDITIONS

All CM Hurricane 360° units feature the Tri-Point Hook Inspection™ system to help protect the operator against unsafe lifting conditions. Hurricane 360° load hooks come with 3 distinct raised points the operator can use to measure the hook to detect any indication of overload or deformation.

